BLEACHERS AND GRANDSTANDS: 2022 CBC

Disciplines: Structural**History:** Revised 09/04/24 Under 2022 CBC
Last Revised 03/21/17 Under 2016 CBC
Original Issue 04/21/05

Division of the State Architect (DSA) documents referenced within this publication are available on the [DSA Forms](#) or [DSA Publications](#) webpages.

PURPOSE

This Interpretation of Regulations (IR) clarifies design and inspection requirements for bleachers and grandstands on projects under DSA jurisdiction.

SCOPE

This IR is applicable to exterior bleachers and grandstands and their components. Such systems may be reviewed and approved by DSA as part of the project's primary construction documents, as a pre-check (PC) application per *Procedure (PR) 07-01: Pre-Check Approval*, or as a deferred submittal when permitted by DSA. This IR is not applicable to other structure types including indoor folding and telescopic seating systems. Refer to *IR 16-4: Folding and Telescopic Seating*.

Refer to *IR A-22: Construction Projects and Items Exempt from DSA Review* for bleachers with five or fewer rows of seating above grade.

See the Glossary below for definitions of terms used in this IR.

BACKGROUND

In accordance with California Building Code (CBC) Section 1030.1.1, bleachers, grandstands, and folding and telescopic seating shall comply with International Code Council (ICC) 300: Standard for Bleachers, Folding and Telescopic Seating, and Grandstands (ICC 300). ICC 300 defines additional loads, load combinations, and other structural design requirements specific to systems of these types but relies on the building code for other requirements. As such, these systems must also comply with the applicable requirements of the CBC and the American Society of Civil Engineers (ASCE) Standard 7: Minimum Design Loads and Associated Criteria for Buildings and Other Structures (ASCE 7).

Prior to the 2022 CBC edition of this IR, DSA provided guidance on bleachers, grandstands, and folding and telescopic seating in a single document: IR 16-5. With the update of the IR for the 2022 CBC, this guidance is now being provided in two IR documents as follows:

- *IR 16-4: Folding and Telescopic Seating*
- *IR 16-5: Bleachers and Grandstands*

1. GENERAL**1.1 Design Professional**

Bleachers shall be designed by a qualified design professional licensed in California. The design professional shall be a licensed architect or structural engineer, unless the system is approved as a deferred submittal, in which case a registered civil engineer is acceptable.

1.1.1 The responsible design professional shall prepare and submit construction documents along with supporting documents, such as calculations, to DSA for review and approval.

BLEACHERS AND GRANDSTANDS: 2022 CBC

1.1.2 Documents shall bear the stamp and signature of the architect or engineer in accordance with *IR A-19: Design Professional Stamp (Seal) and Signature on Documents*.

1.1.3 The design professional in general responsible charge of the project may use construction documents prepared by the fabricator's engineer in accordance with *IR A-18: Use of Construction Documents prepared by Other Design Professionals*.

1.2 Approval by Comparison

Project applicants may request DSA review and approve bleachers based on comparison with a similar system that was previously approved by DSA under a different application number. Approval by comparison is subject to the conditions and limitations of this section, and DSA reserves the authority to make the final determination of when review and approval based on comparison will be permitted.

1.2.1 The structural elements and connections (e.g., welds, bolts, etc.) must be the same or stronger than the previously approved comparison design. The length of structural elements must be the same or shorter than previously approved.

1.2.2 The spans of the structural system must be the same or less than the previously approved comparison design.

1.2.3 The design approved by comparison, is also subject to the following additional limitations:

1.2.3.1 There are no conceptual changes to the configuration of the structural system.

1.2.3.2 There have been no changes in the CBC or DSA policy that would nullify the design.

1.2.3.3 The design loads are no greater than those used in the previously approved design as documented on the construction documents.

1.2.3.4 Material specifications (i.e., minimum material properties such yield strength, ultimate strength, etc.) are unchanged or greater.

1.2.4 The soil conditions must provide equal or greater capacity to support the structure than that of the previously approved design as documented on the construction documents. If the soil conditions do not comply with this condition, DSA will review the affected portions of the design and may approve the design by comparison when it has been demonstrated that the proposed foundation system is code compliant.

1.2.5 Site-dependent ancillary components such as ramps and walkways may require full plan review for approval.

1.2.6 Revisions and corrections may be required in the following cases:

1.2.6.1 Errors or omissions in the original design.

1.2.6.2 Changes in the CBC or DSA policy since the time the comparison design was approved.

1.3 Approval by Testing

When approved by DSA, load tests may be used to substantiate the structural capacity of a bleacher component (e.g., guardrail) and serve as the basis for approval in lieu of engineering analysis. Load tests to substantiate components may be permitted on a case-by-case basis.

1.3.1 Testing shall be performed by an independent laboratory accredited in accordance with ISO/IEC 17025: General requirements for the competence of testing and calibration laboratories.

1.3.2 The test specimen must be an identical prototype of the design submitted for approval. The test specimen material must match the material specified on the project.

BLEACHERS AND GRANDSTANDS: 2022 CBC

1.3.3 New testing will be required if the bleacher component design is changed relative to a previously tested specimen to the extent that cannot be verified by engineering analysis.

1.3.4 The testing procedure and acceptance criteria must be approved by DSA prior to performing the tests. When available, the test procedure and acceptance criteria shall be in accordance with a consensus standard. The test load shall be applied in four or more increments, with the load added by each step being approximately equal. The test apparatus shall apply the test load in a manner that avoids the following:

1.3.4.1 Stiffening the test specimen.

1.3.4.2 Arching of the test load.

1.3.4.3 Impact loading the test specimen.

1.3.5 The test load must be approved by DSA prior to performing the tests and shall not be less than twice the unfactored design load (e.g., *D*, *L*, *Z*, *E*, etc. as defined by the CBC, ASCE 7, and ICC 300). When the test endeavors to substantiate capacity under loads from multiple sources, DSA will make the final determination of the magnitude of the required test load.

1.4 Existing Bleachers

Existing bleachers shall comply with ICC 300 Chapter 5.

1.4.1 After installation, the school district is responsible to conduct annual inspections of the bleachers as required by ICC 300 Section 105.2. The district shall maintain copies of all annual inspection reports and make them available to DSA upon request.

1.4.2 The school district is responsible to conduct annual inspections of existing bleachers as required by ICC 300 Section 501.2.

1.4.3 The school district is required to maintain and repair bleachers in accordance with ICC 300 Section 502.

1.4.4 Additions or alterations to bleachers require DSA approval. Similarly, reconstruction or rehabilitation of bleachers requires DSA approval.

2. STRUCTURAL DESIGN

The structural design of gravity and lateral force-resisting systems, members (including footboards and seatboards), and connections shall be in accordance with ICC 300 Section 303, the CBC, and this section. As applicable to the design and adopted by the CBC, elements and connections shall be designed in accordance with material specifications and standards published by the American Institute of Steel Construction (AISC), the American Iron and Steel Institute (AISI), the Aluminum Association (AA), and the American Concrete Institute (ACI). See also Section 4 below for component-specific structural design provisions.

2.1 Sway Loads

Bleachers and all supporting elements (e.g., connection to foundation, foundation element, etc.) shall be designed for sway loads per ICC 300 Section 303.4 and CBC Section 1607A.19.1.

2.1.1 In accordance with ICC 300 Sections 303.4.1 and 303.4.2, sway loads shall be applied at each footboard level and are reversable (i.e., they act alternately in both directions).

2.1.2 The design shall demonstrate a complete load path for the resistance of sway loads from their origin per Section 2.1.1 above to the foundation, including the adequacy of intermediate stringers when applicable.

2.1.3 When level footboards are supported by sloped stringers a vertical eccentricity is created between the horizontal sway load and the stringer resisting that load. In the absence of an alternative load path, the stringer shall have torsional capacity to resist the sway loads applied parallel to the seating.

BLEACHERS AND GRANDSTANDS: 2022 CBC**2.2 Live Loads**

Bleachers shall be designed for live load requirements of CBC Section 1607A and ICC 300 Section 303. Structural adequacy shall be demonstrated for the most severe prescriptive load requirement.

2.2.1 Bleachers shall be designed for a 100 pound per square foot (psf) live load per CBC Table 1607A.1, Item 4 and ICC 300 Section 303.2. This live load is not reducible per CBC Table 1607A.1, Footnote 'a'.

2.2.2 Because bleachers are places of public assembly, Exception 1 of ASCE 7 Sections 2.3.1 and 2.3.6 is not applicable.

2.2.3 In accordance with CBC Section 1607A.13 and ICC 300 Section 303.5, the design shall be evaluated for "skip" live load cases and demonstrate adequacy under the most critical loading condition.

2.2.4 The design shall demonstrate compliance with the live load deflection limit of ICC 300 Section 303.6.

2.2.5 Press box floors and accessible roofs shall be designed for a 100 psf live load per CBC Table 1607A.1, Footnote 'g'.

2.3 Load Combinations

Load combinations shall be in accordance with CBC Section 1605A and ICC 300 Section 303.5 as modified by CBC Section 1605A.3.

2.3.1 Horizontal sway loads (*Z*) stipulated in ICC 300 need not be considered live loads (*L*) in the load combinations required by CBC Section 1605A.1 and defined in ASCE 7 Sections 2.3 and 2.4. While sway loads are defined as live loads in CBC Section 1607A.19 the specific reference to ICC 300 therein is interpreted to define sway loads as "Z" and separate from "L".

2.3.2 When considering the live load requirements of CBC Section 1607A.9.1, ASCE 7 Section 2.3.1, Combination #2 will control over ICC 300 Equation 3-4 and ASCE 7 Section 2.4.1, Combination #2 will control over ICC 300 Equation 3-8.

2.3.3 The load combinations defined by ICC 300 Section 303.5.2 shall be applied as basic allowable stress design load combinations per CBC Section 1605A.1, not alternative allowable stress design load combinations per CBC Section 1605A.2.

2.4 Seismic Loads

Bleachers shall be designed for seismic forces in accordance with ASCE 7.

2.4.1 In the transverse direction (i.e., perpendicular to the seating) the seismic force shall be determined in accordance with ASCE 7 Table 15.4-2: Seismic Coefficients for Nonbuilding Structures Not Similar to Buildings using a seismic response factor (*R*) of 1.25 for "All other self-supporting structures..."

Exception: When the seismic force-resisting system can be classified according to ASCE 7 Table 15.4-1: Seismic Coefficients for Nonbuilding Structures Similar to Buildings, the seismic force is permitted to be determined using the corresponding seismic coefficients.

2.4.2 In the longitudinal direction (i.e., parallel to the seating) the seismic force shall be determined in accordance with ASCE 7 Table 15.4-2 using a seismic response factor (*R*) of 1.25 for "All other self-supporting structures..."

Exception: When the seismic force-resisting system for independent lines of resistance can be classified according to ASCE 7 Table 15.4-1, it is permitted to use the corresponding seismic coefficients for each line of resistance.

BLEACHERS AND GRANDSTANDS: 2022 CBC

2.4.3 The design shall comply with all prescriptive requirements and limitations required of the selected seismic force-resisting system per the applicable table in ASCE 7 Chapter 15.

2.4.3.1 Bleacher height (see Glossary below) shall not exceed the structural height (h_n) limit.

2.4.3.2 The importance factor (I_e) shall be in accordance with ASCE 7 Table 1.5-2.

2.4.3.3 In accordance with ASCE 7 Section 12.3.4.1 Item 4, the redundancy factor (ρ) may be taken as unity when the design is based on ASCE 7 Table 15.4-2.

2.4.3.4 In accordance with CBC Section 1604A.9, detailing shall comply with AISC Seismic Provisions for Structural Steel Buildings (AISC 341) when required by ASCE 7 Table 15.4-1, regardless of whether the seismic demand is exceeded by the wind load demand.

2.4.4 Braced frames with tension-only braces (e.g., rods, angles, etc.) are permitted to be considered “steel ordinary concentric braced frames” (i.e., $R = 3.25$) in accordance with ASCE 7 Table 15.4-1.

2.4.5 The vertical seismic load effect in accordance with ASCE 7 Section 2.3.6 or 2.4.5 and Section 12.4.2.2 shall be applied in the direction (i.e., upward or downward) that results in the most demanding condition relative to stability, strength requirements, or deformation limits.

2.5 Wind Loads

Outdoor bleachers shall be designed for wind loads in accordance with CBC Section 1609A.

2.5.1 Seatboards and footboards shall be designed to resist “Components and Cladding” (C&C) pressures per ASCE 7.

2.5.2 Stringers with a wind tributary area less than 700 square feet shall be designed for C&C pressures in accordance with ASCE 7. Downward and uplift wind forces shall be applied normal to the axis of stringers, which are commonly sloped.

2.5.3 Girders, regardless of wind tributary area, may be considered part of the “Main Wind-Force Resisting System” (MWFRS) and need not be designed for C&C pressures.

2.6 Foundation

Foundations for all bleachers shall comply with CBC Section 1808A.

Exception: Temporary and portable bleachers as defined in the Glossary below may be supported by wood sills or steel plates directly bearing on the ground surface, provided the soil bearing pressure does not exceed 1,200 pounds per square foot. The Exception of ICC 300 Section 303.7 is only permitted under these conditions.

2.6.1 In accordance with ASCE 7 Section 15.1.1, the design of foundation elements resisting seismic loads shall comply with ASCE 7 Section 12.13.

2.6.2 When seismic loads result in uplift, top reinforcement shall be provided in the footing or other foundation element in accordance with ACI 318: Building Code Requirements for Structural Concrete, Section 18.13.2.5.

3. TESTING AND INSPECTION

Testing and inspection requirements are summarized in this section. Refer to *PR 13-01: Construction Oversight Process* for additional requirements applicable to special inspection, material testing, and the test laboratory, including verified report submittal requirements.

3.1 Fabrication Inspection

Special inspection is required per CBC Section 1704A.2 for shop fabrication. The special inspector shall verify the fabricator’s quality control procedures and inspect the fabrication to verify compliance with the approved construction documents and referenced standards per CBC Sections 1705A.2.1 and 1705A.2.5.

BLEACHERS AND GRANDSTANDS: 2022 CBC

3.1.1 The special inspector shall be employed by the laboratory of record or contract directly with the school district in accordance with the requirements of the California Administrative Code (CAC). Special inspectors contracting directly with the school district must be approved by DSA prior to performing inspections and shall submit a verified report (i.e., form *DSA 292: Special Inspectors Employed Directly by the District Verified Report*) in accordance with the CAC.

3.1.2 The special inspector is responsible for ensuring all materials are identifiable and traceable to the certificates of compliance, such as mill certificates. The special inspector shall attach copies of these certificates to their daily inspection reports per *IR 17-12: Special Inspection Reporting Requirements*.

3.1.3 If welding is required in the fabrication shop, an AWS-certified welding inspector or senior welding inspector shall inspect the welding in accordance with the CBC and *IR 17-3: Structural Welding Inspection*. The welding inspector shall provide daily inspection reports per IR 17-12.

3.1.4 A press box, whether structurally integral with or structurally independent of the bleachers, requires factory-built building “in-plant” inspection. Refer to *IR A-15: Testing and Inspection of Remotely Fabricated Structural Elements*, Section 3.1 for additional information.

3.2 Material Testing

If any material testing is required, such as for unidentifiable steel, testing must be performed by a testing laboratory employed by the school district and acceptable to DSA. A list of acceptable testing laboratories can be found on the DSA website. For remotely located fabricators, refer to IR A-15.

Test reports shall be submitted by the laboratory in accordance with the CAC, and a final verified report (i.e., form *DSA 291: Laboratory of Record Verified Report*) shall be submitted at the conclusion of the fabrication.

3.3 Field Inspection

When the bleacher is delivered to the job site, field inspection shall be performed in accordance with this section.

3.3.1 The project inspector is responsible for field inspection including, but not limited to, the following actions:

3.3.1.1 Verify all required documents per Section 3.1 and 3.2 above are submitted.

3.3.1.2 Review the documents submitted for compliance with the DSA approved construction documents.

3.3.1.3 Inspect the bleachers for compliance with the approved construction documents. Identify any defects and, if appropriate, issue a form *DSA 154: Notice of Deviations/Resolution of Deviations*.

3.3.1.4 Inspect the field installation, including site assembly.

3.3.2 If field welding is performed, an AWS-certified welding inspector or senior welding inspector shall inspect the welding in accordance with the CBC, IR 17-3, and Section 3.1.3 above.

4. COMPONENTS

Many bleacher designs employ various common components. Notable component-specific requirements are summarized in this section.

BLEACHERS AND GRANDSTANDS: 2022 CBC**4.1 Seatboards and Footboards**

On the basis of full-scale tests, product tests, previously approved designs, and engineering data previously submitted, DSA has determined that seatboards and footboards are acceptable alternate structural elements, per CAC Sections 4-304 and 4-305, as described in this section.

4.1.1 Seatboards and footboards with mechanical or clamp-style fasteners at supports are permitted to serve as structural elements in the following applications:

4.1.1.1 Lateral bracing of the top flange of stringers.

4.1.1.2 Torsional restraint of the stringers under sway, seismic, and wind forces.

4.1.1.3 Diaphragm action for distribution of sway, seismic, and wind forces.

4.1.2 Seatboards and footboards with snap-on type connectors at supports will not be permitted to provide lateral bracing to the top flange of stringers, torsional restraint of the stringers, nor allow footboards to act as a diaphragm to distribute forces as described in Section 4.1.1 above unless design-specific justification is provided.

4.1.3 Aluminum to steel connections shall be fully detailed on the construction drawings, including the required installation torque for friction clips. Each aluminum plank (i.e., seatboard or footboard plank) shall be connected to each supporting stringer with a minimum of two friction clips.

4.1.4 Seatboards and footboards shall not be used as collector elements to drag lateral forces across the bleachers to their point of resistance unless comprehensive analysis and detailing substantiates their design as such. Dedicated collector elements separate from the seatboards and footboards should be provided.

4.2 Stringers

Bleachers are commonly framed with steel wide-flange sections oriented perpendicular to the seating in plan known as “stringers”.

4.2.1 As noted in Section 4.1.1.1 above, seatboards and footboards may provide lateral bracing of the stringer top flange. The design shall provide lateral bracing as required and demonstrate the structural adequacy for the resulting unbraced lengths, including the following conditions:

4.2.1.1 Top flange or lengths thereof where unique aspects of the bleacher geometry interrupts the load path between the stringer top flange and the seatboards and footboards.

4.2.1.2 Bottom flange in compression (e.g., negative moment at cantilever).

4.2.1.3 Section in axial compression (e.g., under collector load).

4.2.1.4 Compliance with the AISC Specification for Structural Steel Buildings (AISC 360) Section F1(b) requirement for rotational restraint when using a lateral-torsional buckling modification factor (C_b) greater than 1.0.

4.2.2 Lateral braces for stringers shall comply with the strength and stiffness requirements of AISC 360 Appendix 6.3.

4.2.3 The stringer at the end of the bleacher commonly supports the guard rail required at that location. Stringers shall be designed with adequate capacity to resist the torsion induced by rail posts or an alternative load path (e.g., flange bracing) is required to resolve the railing loads.

BLEACHERS AND GRANDSTANDS: 2022 CBC

4.2.4 Stringers are commonly spliced with shop welds of the flanges and web at locations where the axis of the wide-flange section changes (i.e., stringer slope or orientation changes). Complete joint penetration welds and stiffener plates on each side of the web are typically required at these transitions to resolve the change in stress direction and stress concentrations. If stiffener plates are not provided, the design shall demonstrate the adequacy of the connections in their absence.

4.2.5 Stringers may be field spliced using end-plate bolted connections, which shall comply with AISC Design Guide 16: Flush and Extended Multiple-Row Moment End-Plate Connections (AISC DG16).

4.2.5.1 High strength bolts in these connections shall be pretensioned in accordance with AISC DG16 Section 2.5.3, Item 3. If oversized holes are specified, slip critical bolts are required.

4.2.5.2 The flange-to-end plate weld shall develop not less than 60 percent of the flange yield strength in accordance with AISC DG16 Section 2.5.3, Item 8.

4.2.6 Where a stringer runs continuous over a supporting girder or column, a complete load path is required for the lateral loads delivered by the seatboards and footboards above the stringer to the girder (i.e., collector) or column below it. While a pair of stiffeners are recommended, where stiffeners are not provided the design must justify the stringer flange for the resulting local weak axis bending. In the absence of another acceptable methodology (e.g., finite element analysis, consensus design standard, etc.) DSA will permit justification based on an effective flange length equal to two times the distance from the applied load (typically the bolt location) to the critical section (typically the k_1 distance from the web centerline).

4.3 Girders

Bleacher framing commonly includes steel wide-flange girders oriented parallel to the seating that span between columns and support stringers.

4.3.1 Where a stringer runs continuous over the supporting girder, the connection only provides lateral bracing of the girder's top flange. Stiffeners or kicker braces shall be provided where lateral bracing is required of the girder bottom flange (or top of the column as applicable).

4.3.2 Where a girder cantilevers past the last column and its free end is not otherwise restrained against rotation, full-depth stiffener plates or flange bracing is required. Alternatively, the cantilever girder may be designed using $C_b = 1.0$.

4.3.3 Where the girder runs continuous over the column, lateral bracing shall be provided perpendicular to the girder at the bottom flange or top of the column.

4.4 Tension-Only Rod Bracing

Bleachers may employ tension-only rod bracing to resist lateral (i.e., wind, seismic, and sway) forces. Refer to Section 2.4.4 above.

4.4.1 When rod bracing is connected perpendicular to the column web as illustrated in Figure 4.4 below, the effective width of the web resisting the brace force shall be limited by the yield-line analysis as set forth in the AISC Steel Construction Manual, Part 9, Figure 9-5(a) and Equation 9-31.

4.4.2 When used, "Hillside" washers shall be of the same material and welded to the column (i.e., the supporting member) to prevent it from becoming unseated during the reversal of cyclic seismic loads. See Figure 4.4 below.

4.4.3 The construction documents shall specify the following with respect to the turnbuckle:

4.4.3.1 Minimum engaged thread length in accordance with dimension "n" given in AISC Steel Construction Manual, Part 15, Table 15-6.

4.4.3.2 Maximum permitted sag in the rod after erection and tightening.

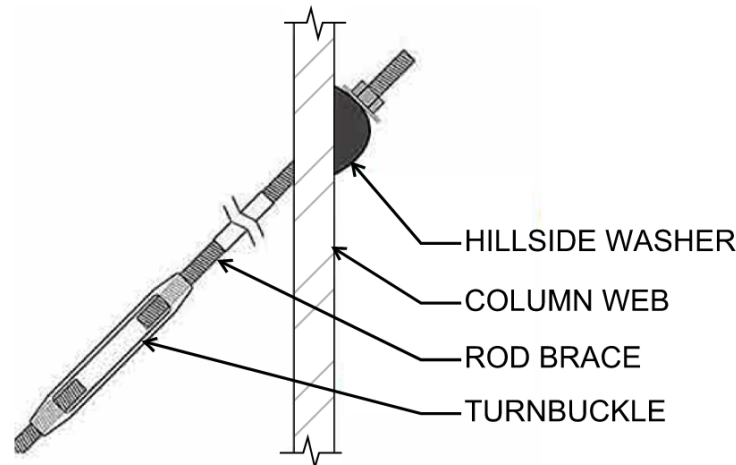
BLEACHERS AND GRANDSTANDS: 2022 CBC**Figure 4.4**

4.4.4 The pretension force in the rod braces (T) shall be accounted for in the structural analysis and design in accordance with ASCE 7 Section 2.3.4 or 2.4.4. DSA will accept the load factor used for dead loads to also be applied to the pretension force. When the analysis is based on a computer model, the pretension force may be applied as a temperature load.

4.5 Railing

Handrails and guards shall be designed for the loads prescribed in ICC 300 Table 303.2 and CBC Section 1607A.9.1, which apply in any direction.

4.5.1 Construction drawings shall define handrail splice locations, and the design shall justify the structural adequacy of the rail (including the splice connection) based on these locations.

4.5.2 When steel angles (or other asymmetrical sections) serve as rail posts, the design shall justify the structural adequacy of the post in its weak axis.

4.6 Ramps and Stairs

The construction drawings shall provide the complete design of ramps, stairs, and other ancillary structures associated with the bleachers. The design of these structures shall be substantiated with structural calculations in accordance with CBC Section 1603A.3.

REFERENCES:

2022 California Code of Regulations (CCR) Title 24

Part 1: California Administrative Code (CAC), Sections 4-304, 4-305, 4-314.

Part 2: California Building Code (CBC), Sections 1030, 1603A, 1604A, 1605A, 1607A, 1609A, 1704A, 1705A, 1808A.

This IR is intended for use by DSA staff and by design professionals to promote statewide consistency for review and approval of plans and specifications as well as construction oversight of projects within the jurisdiction of DSA, which includes State of California public schools (K-12), community colleges and state-owned or state-leased essential services buildings. This IR indicates an acceptable method for achieving compliance with applicable codes and regulations, although other methods proposed by design professionals may be considered by DSA.

This IR is subject to revision at any time. Please check DSA's website for currently effective IRs. Only IRs listed on the webpage at www.dgs.ca.gov/dsa/publications at the time of project application submittal to DSA are considered applicable.

BLEACHERS AND GRANDSTANDS: 2022 CBC**GLOSSARY****Bleacher**

As defined in ICC 300 Section 202. This term is synonymous with “grandstand”, and the two are used interchangeably in this IR. All provisions pertaining to grandstands are also applicable to bleachers.

Bleacher Height

Overall height of a bleacher measured from the top of foundation at the front to the uppermost seatboard.

Folding and Telescopic Seating

As defined by ICC 300 Section 202. Refer to *IR 16-4: Folding and Telescopic Seating*.

Grandstand

As defined by ICC 300 Section 202. This term is synonymous with “bleacher”, and the two are used interchangeably in this IR. All provisions pertaining to bleachers are also applicable to grandstands.

Portable Bleachers

Seating facilities located outside of a building and not attached to permanent foundations. Portable bleachers are not permitted in excess of eleven rows nor with a bleacher height over 9-feet. See also the definition of Temporary Portable Bleachers below.

School Building

As defined by CAC Section 4-314. Bleachers and grandstands (including portable bleachers) with more than five rows of seats above grade are defined as school buildings.

Temporary Portable Bleachers

Portable bleachers as defined above that remain at a location for less than 90 days. Temporary portable bleachers are exempt from DSA review and approval but must comply with the ICC 300 and Section 2.6 above.